

ORDINANCE 581-R-2020

AN ORDINANCE AMENDING A CERTAIN SECTION OF ORDINANCE 581, CHAPTER 4-5 ZONING RELATED TO COMMERCIAL TRASH ENCLOSURES, PROVIDING SEVERABILITY, AND SETTING AN EFFECTIVE DATE.

WHEREAS, the City of Universal City is a home rule City acting under its home rule Charter and the law of the State of Texas; and

WHEREAS, Tex. Loc. Gov't Code Chapter 211 authorizes the City of Universal City to adopt rules and regulations regarding land use within the City limits of the City of Universal City for the purpose of promoting the safe, orderly, and healthful development of the City; and

WHEREAS, the City Council finds it necessary to establish the provisions of this ordinance regarding the regulation of commercial trash enclosures; and

WHEREAS, the City Council finds that it would be advantageous and beneficial to the citizens of the City of Universal City, Texas, to adopt this ordinance regulating the requirements for commercial trash enclosures within the City of Universal City; and

WHEREAS, the City Council of the City of Universal City, Texas, has determined that it is in the best interest of the public and in support of the health, safety, morals, and general welfare of the citizens of the City that the Zoning Code regulations relative to commercial trash enclosure standards be established as hereinafter stated.

NOW, THEREFORE, BE IT ORDAINED BY THE CITY COUNCIL OF THE CITY OF UNIVERSAL CITY, TEXAS:

Section 1. Amendments. That Chapter 4-5 – Zoning, Section 4-5-84 of the Universal City Code of Ordinances be amended in its entirety to read:

I. Sec. 4-5-84. – Commercial Trash Enclosures

Refuse disposal dumpsters and refuse storage areas for all commercial buildings and multi-family residential complexes that utilize a shared refuse disposal dumpster shall be fully enclosed on three sides by an opaque masonry wall (stone, stucco or brick) or wall of the principal structure meeting the height requirements and other requirements, including a steel or aluminum gate, identified in the Trash Enclosure Detail below. The materials used for screening, including the enclosure, shall complement the architecture of the principal structure.

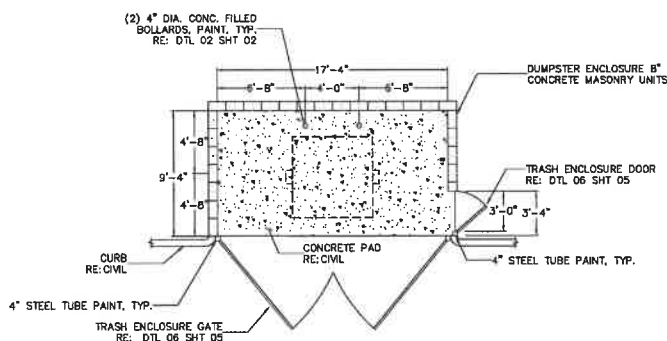

01A TRASH ENCLOSURE PLAN (SINGLE DUMPSTER)
SCALE: N.T.S.

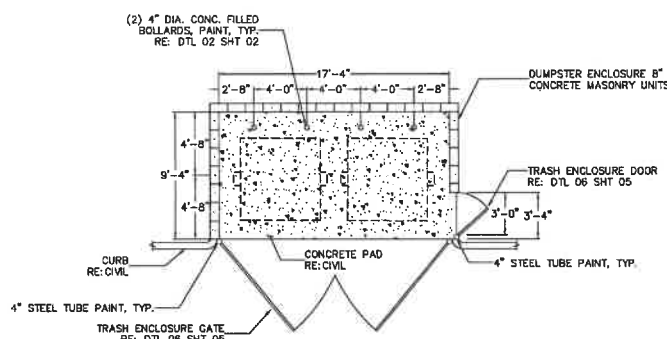

01B TRASH ENCLOSURE PLAN (DUAL DUMPSTERS)
SCALE: N.T.S.

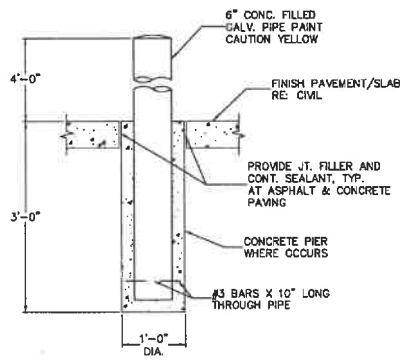

02 CONCRETE BOLLARD
SCALE: N.T.S.

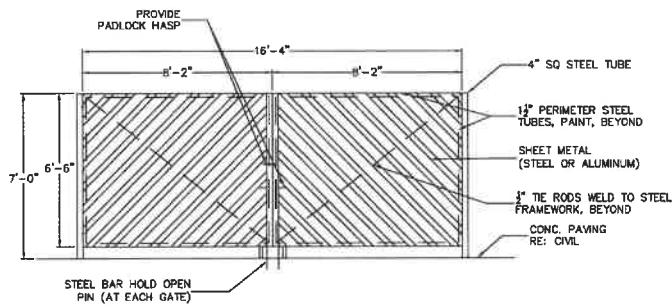

03 TRASH ENCLOSURE ELEVATION
SCALE: N.T.S.

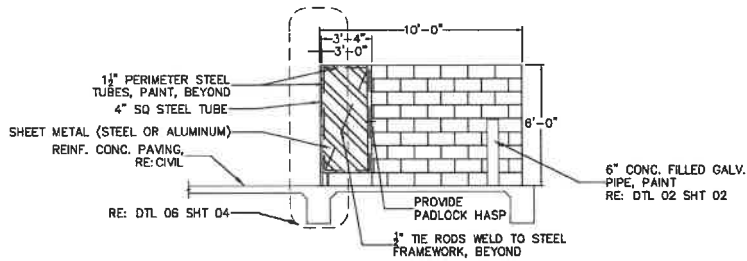

04A TRASH ENCLOSURE ELEVATION 6FT HEIGHT
SCALE: N.T.S.

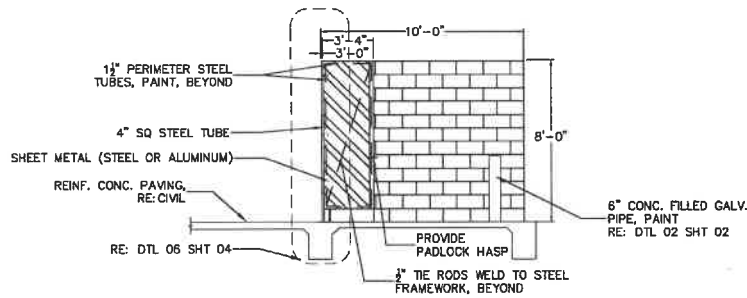

04B TRASH ENCLOSURE ELEVATION 8FT HEIGHT
SCALE: N.T.S.

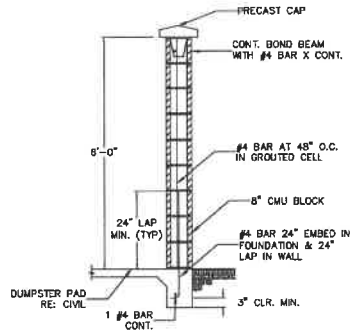

05A TRASH ENCLOSURE 6FT CMU WALL SECTION
SCALE: N.T.S.

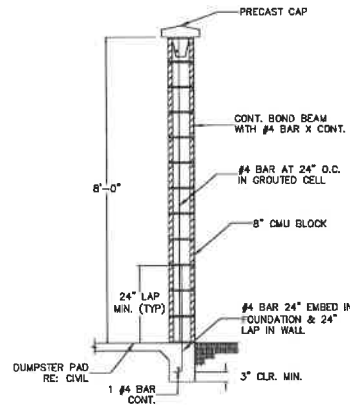

05B TRASH ENCLOSURE 8FT CMU WALL SECTION
SCALE: N.T.S.

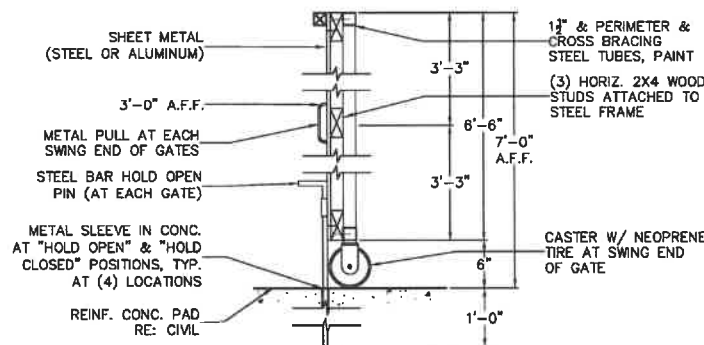

06 TRASH ENCLOSURE GATE
SCALE: N.T.S.

NOTE:
BOTH GATES MUST
OPEN A FULL 180
DEGREES

Section 2. Conflict with City Ordinances. All Ordinances or parts of Ordinances in conflict herewith are, to the extent of such conflict, hereby repealed.

Section 3. Unamended. That the remainder of Chapter 4-5 – Zoning of the Universal City Code of Ordinances not amended hereby remain in full force and effect.

Section 4. Severability. If any provision, clause, sentence or paragraph of this Chapter or the application thereof to any person or circumstances shall be held invalid, such invalidity shall not affect the other provisions of this Chapter which can be given effect without the invalid provision or application, and to this end the provisions of this Chapter are declared to be severable.

Section 5. Effective Date: This ordinance shall become effective on 05 August 2020.

PASSED on first reading 21 July 2020.

PASSED AND ADOPTED on the 4th day of August 2020.

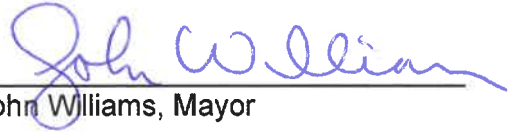

John Williams, Mayor

Attest:

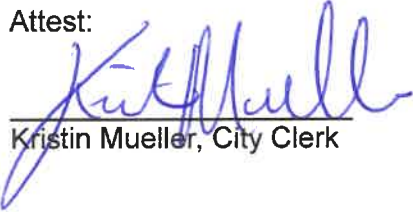

Kristin Mueller, City Clerk

Approved for legal sufficiency:



Matthew J. Longoria, City Attorney

